

Street Furniture

Section 7: Contents

Cast Iron Columns and Lighting	124
Ornamental Signposts	126
Cast Iron Posts for Rails.....	127
Cast Iron Seat Ends and Benches	130
Cast Iron Bollards.....	133
Tree Grilles	136

ORDER TODAY!
CALL: +44 (0)1506 822 721

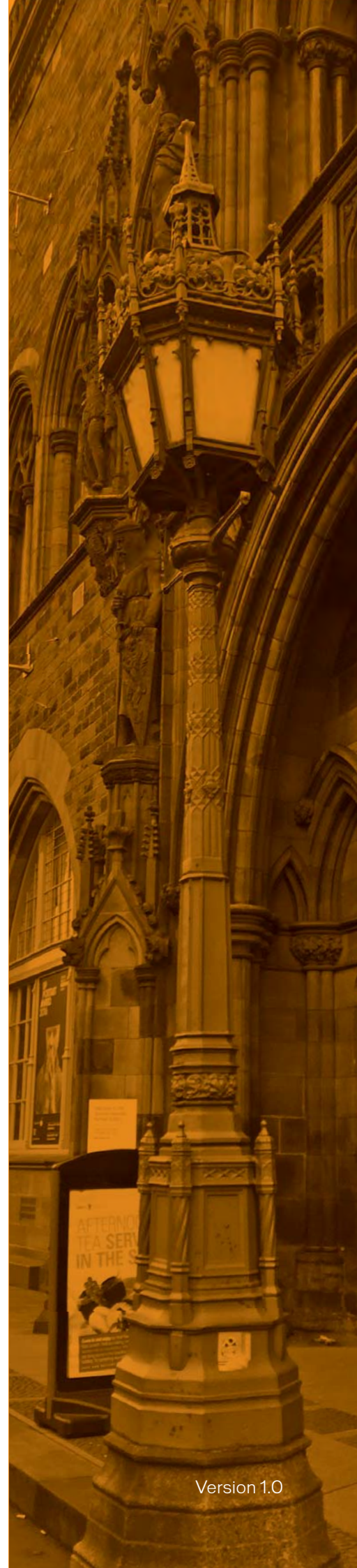



Cast Iron Columns and Lighting

We supply lamp-posts and columns to specialist suppliers, individual sites, local authorities and private clients throughout the UK. They prove popular where people are interested in providing a more sympathetic style of historic lighting or structural support. Cast iron is an excellent material for structural purposes with high compressive strengths per N/mm² offering a functional and visually appealing alternative to steel products.

Our range is broad and mixes fashionable new designs with more traditional ironwork. Columns are technically similar to make and are used for canopies, archways, walkways and entrances. We can cast anything from 1 metre to 10 metres depending on requirement. Our patterns take inspiration from traditional Roman, Doric and Corinthian designs and although we are always enthusiastic about the designs of the past, we regularly make modern design columns for clients throughout the world.

We are currently in the process of updating our catalogue with over 100 cast iron columns, but please get in touch in the meantime with any enquiry you may have.

All castings are hand-made to order using traditional foundry methods and can be produced in grey iron, ductile iron or in aluminium.

Purchasing Guide

- We would usually recommend using ductile iron for our larger columns and lighting products.
- All lighting columns and lamp-posts are supplied fully fitted with wooden back boards for electrical use.

ORDER TODAY!

CALL: +44 (0)1506 822 721



Ornamental lighting in cast iron by Ballantine Castings

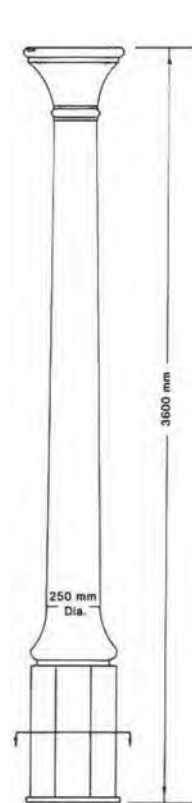

A240 Cl:585kg

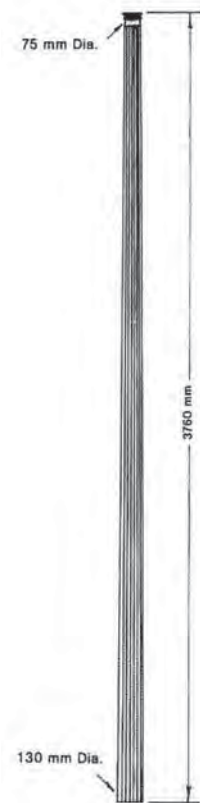

A241 Cl:105kg

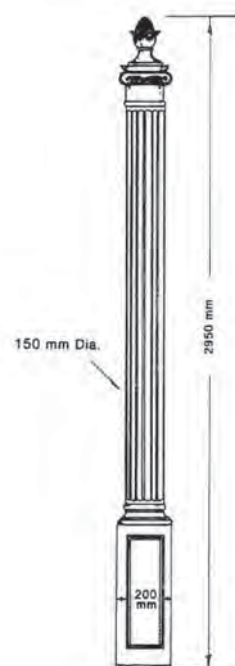

A242 Cl:230kg

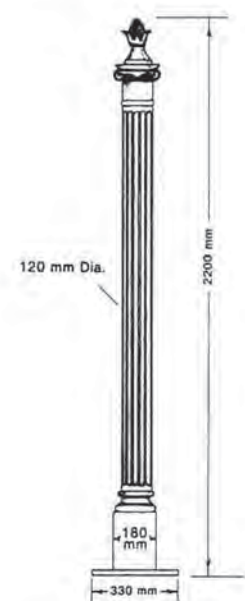

A243 Cl:134kg



Cast Iron Columns and Lighting continued

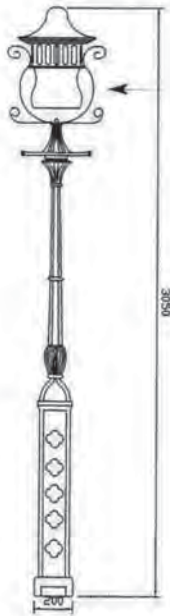

A255 Cl:55kg

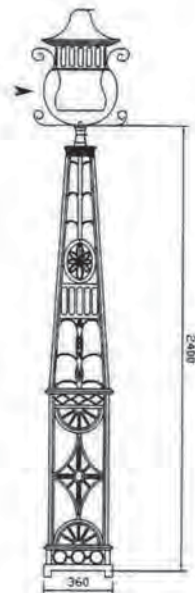

A256 Cl:70kg

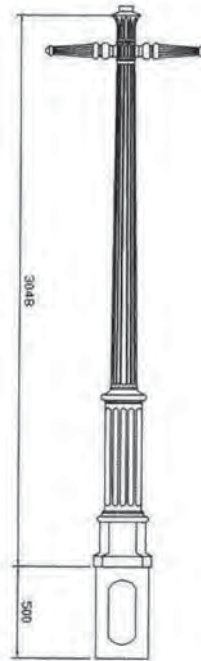

A257 Cl:285kg



A258 Cl:245kg



A259 Cl:297kg

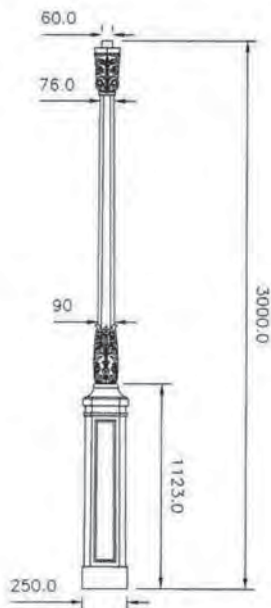

A260 Cl:153kg

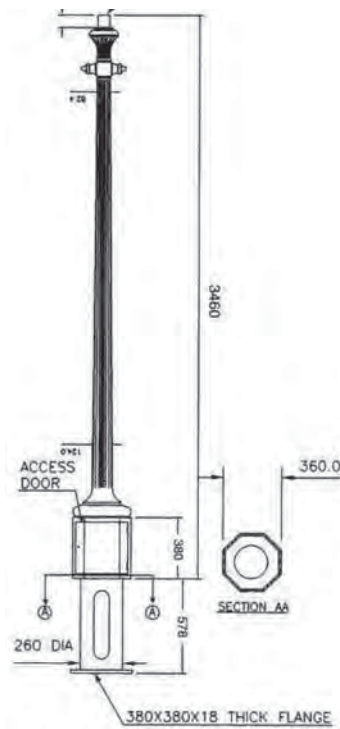

A261 Cl:147kg

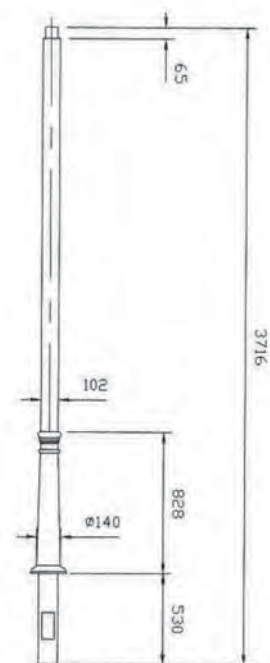

A262 Cl:96kg



Ornamental Signposts

Classic, Victorian fingerposts and signs are unarguably one of the most common and cherished testaments to cast iron still found in both cities and the countryside today. Unlike most suppliers of these items we produce a number of these each year in the UK for both commercial and domestic customers ensuring we use the highest quality products to faithfully re-create the beautiful signage of the 18th Century.

Purchasing Guide

- We have a range of finials to complete each column – these are wholly interchangeable.
- Individual finger arms can be ordered on demand to replace old, damaged ones.
- Arms come in singles, doubles and triples.
- The maximum amount of lettering per sign is 22 individual letters.
- Arms can be double sided for lettering.
- Painting is available in a number of options. Please call our technical sales team with any query you may have.
- All items are provided individually for site erection. Each arm and the finial are supplied with grub screws to be tightened and set in the right direction on site.

ORDER TODAY!

CALL: +44 (0)1506 822 721

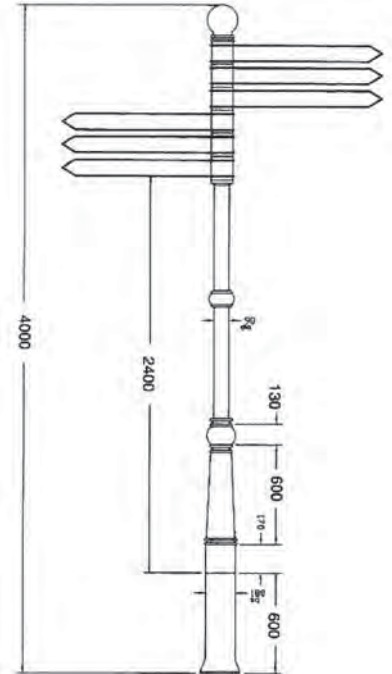

A263 Post: Cl:117kg Finger: Cl:13kg

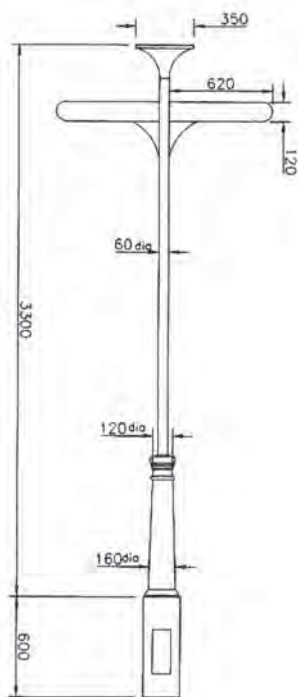

A264 Cl:130kg

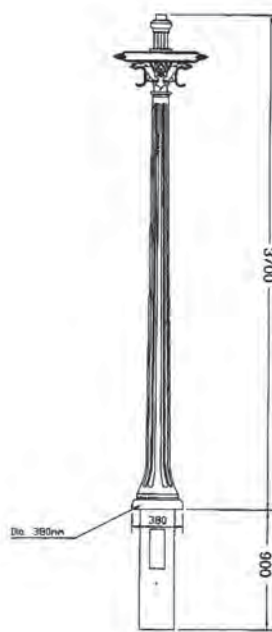

A265 Cl:136kg

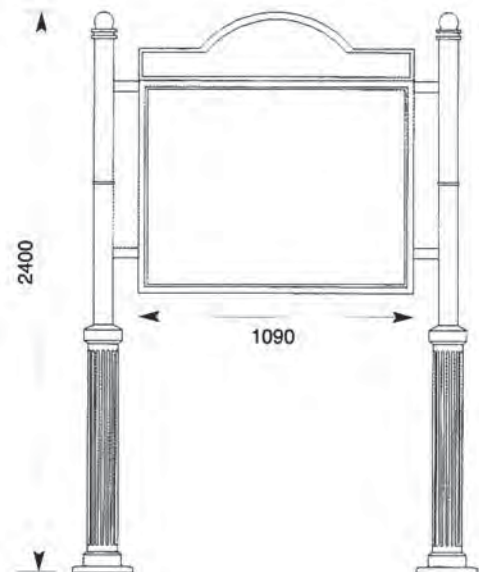

A266 Cl:340kg



Cast Iron Posts for Rails

We are one of very few foundries still manufacturing these products in the UK as most of these items are now imported. Our range of cast iron posts are perfectly suited for both inner city developments and ornamental seafronts alike - their versatility for providing an aesthetic and functional barrier has given rise to their popularity over the last 200 years and will continue to do so in the future.

We have a number of designs to suit varying design and function requirements and have a unique flexibility in our process to make alterations to designs and fixing methods.

Purchasing Guide

- The diameter of the horizontal holes can be manufactured to suit various sizes of mild steel tubes.
- Holes can be filled in to allow for eye bolts and link chains.
- Holes can be altered to slope or to be blanked off if required.
- We can produce these items in both cast and ductile iron. In an area where there is a possibility of vehicular or mechanical impact, or a high chance of vandalism, we would highly recommend using ductile irons.
- All posts can be root or flange fixed.
- These posts can easily be converted for various uses - post and rail, post and chain or post and panel are all possible.
- Final painting is available on these products.

ORDER TODAY!

CALL: +44 (0)1506 822 721

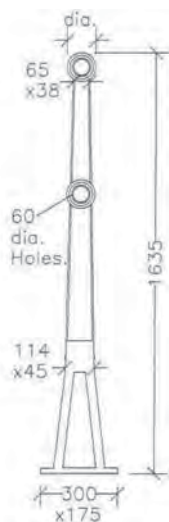

HS001 Cl:62kg

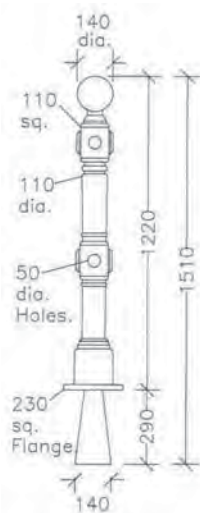

HS002 Cl:142kg

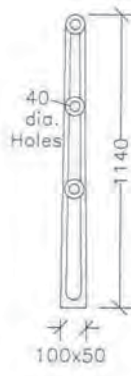

HS003 Cl:30kg



HS004 Cl:33kg

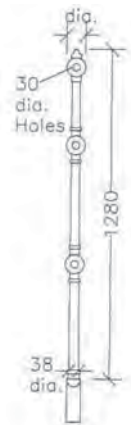

HS005 Cl:16kg

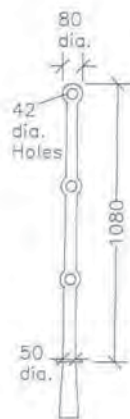

HS006 Cl:24kg



HS007 Cl:32kg



HS008 Cl:13kg



HS009 Cl:17.5kg



HS010 Cl:18.5kg



Handrail Standards and Posts continued



HS011 Cl:11kg



HS012 Cl:14kg

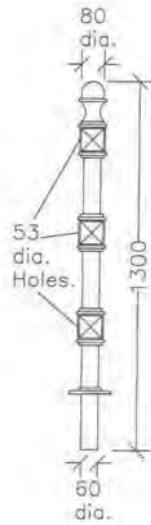

HS013 Cl:41kg

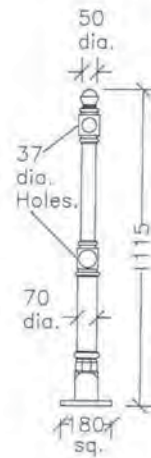

HS014 Cl:34kg

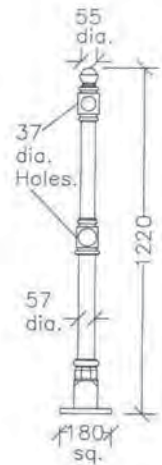

HS015 Cl:37kg

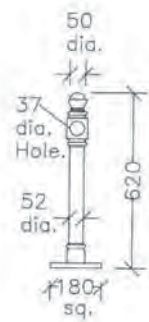

HS016 Cl:19kg

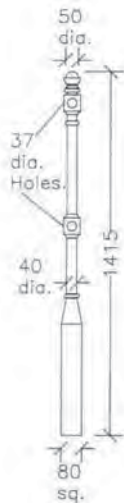

HS017 Cl:34kg

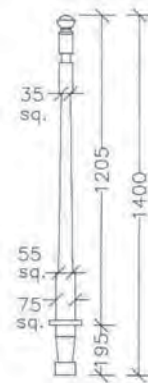

HS018 Cl:35kg

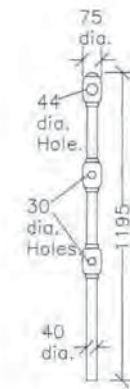

HS019 Cl:17kg

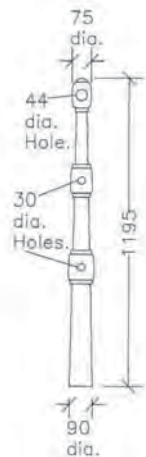

HS020 Cl:36kg



HS021 Cl:43kg



HS022 Cl:34kg



HS023 Cl:16kg

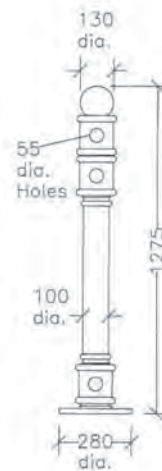

HS024 Cl:52kg

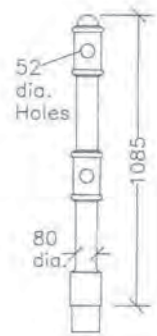

HS025 Cl:26kg



Handrail Standards and Posts continued

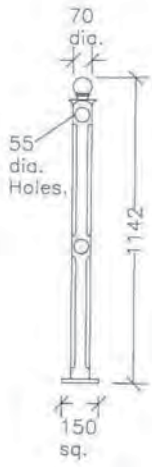

HS026 Cl:48kg

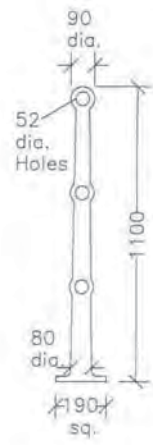

HS027 Cl:33kg

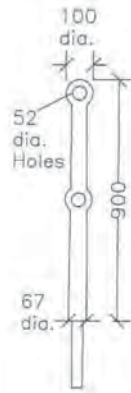

HS028 Cl:26kg



HS029 Cl:13kg

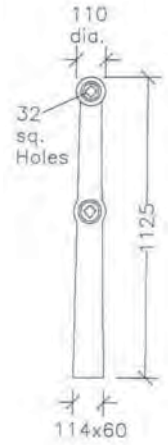

HS030 Cl:41kg

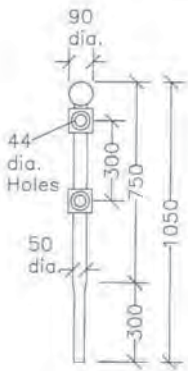

HS031 Cl:30kg

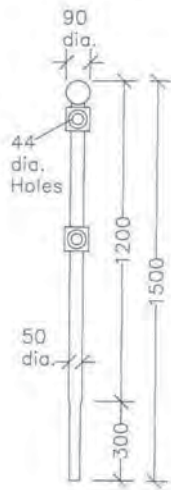

HS032 Cl:21kg

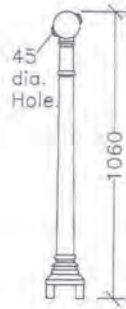

HS033 Cl:30kg



HS034 Cl:51kg

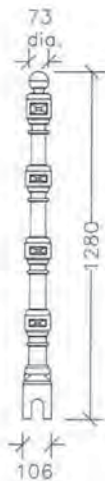

HS035 Cl:43kg



HS036 Cl:40kg





Cast Iron Seat Ends and Benches

We are proud to produce a stunning selection of outdoor benches for parks and gardens in traditional and contemporary designs. Cast irons seating is not only beautiful but also extremely durable. We can offer supply only service on bench ends and do not do the fitting of the wooden or steel slats. We would recommend only using FSC certified hardwood in all of our benches. If you cannot find what you require in our catalogue we are constantly making new designs so are happy to look at any enquiry.

Purchasing Guide

- All benches are fixed above ground using anchor bolts. Bolts can be supplied at an extra cost.
- We can produce these items in both cast and ductile iron. In an area where there is a possibility of vehicular or mechanical impact, or a high chance of vandalism, we would highly recommend using ductile irons.
- Final painting and powder-coating is available on these products.

ORDER TODAY!
CALL: +44 (0)1506 822 721

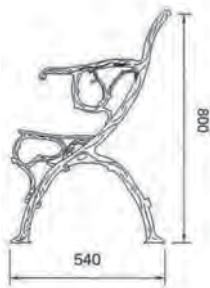

BE001 Cl:20kg



BE002 Cl:26kg

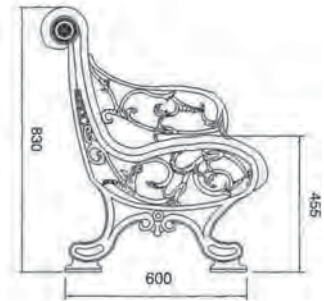

BE003 Front: H455mm Cl:68kg

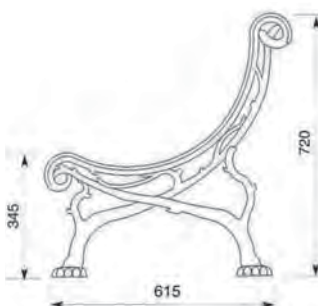

BE004 Front: H345mm Cl:46kg



BE005 Front: H405mm Cl:55kg

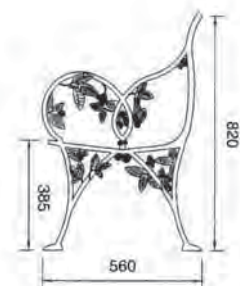

BE006 Front: H385mm Cl:25kg



Cast Iron Seat Ends and Benches continued

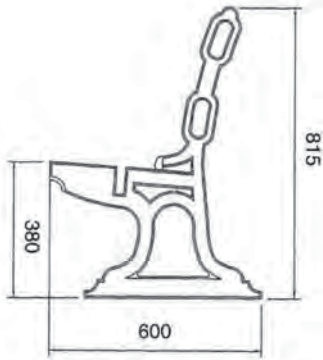

BE007 Front: H380mm Cl:39kg

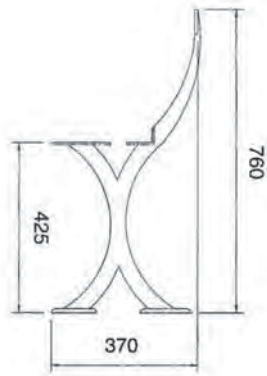

BE008 Front: H425mm Cl:15kg

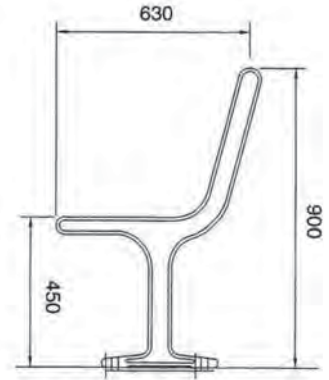

BE009 Front: H450mm Cl:38kg

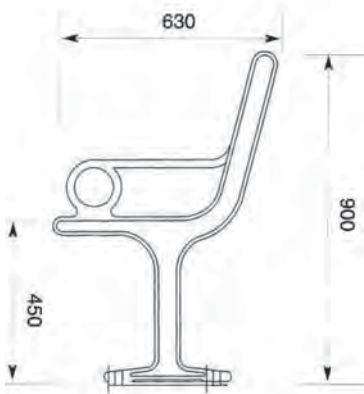

BE010 Front: H450mm Cl:44kg

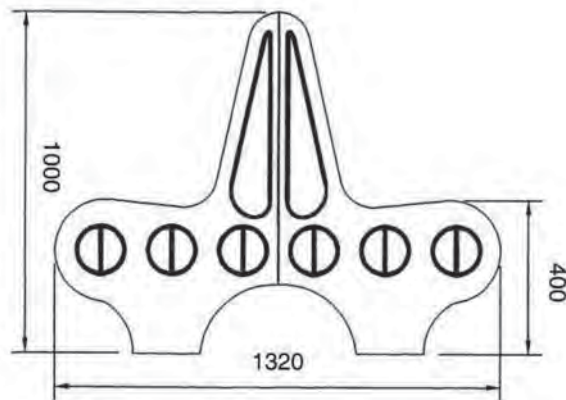

BE011 Front: H400mm Cl:160kg

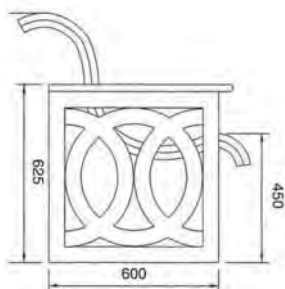

BE012 Front: H450mm Cl:160kg

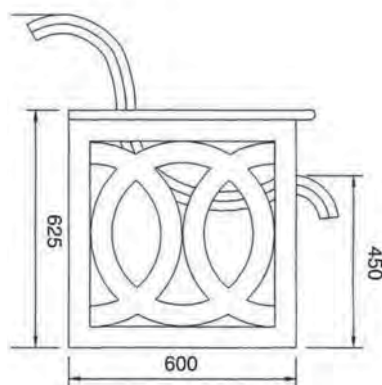

BE013 Front: H450mm Cl:175kg

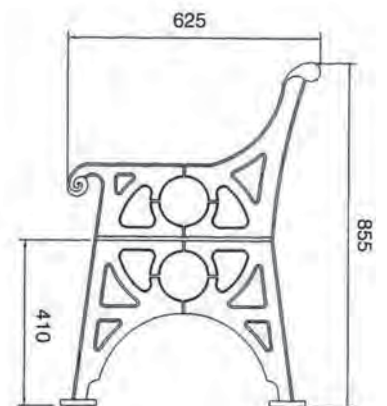

BE014 Front: H410mm Cl:44kg



Cast Iron Seat Ends and Benches continued

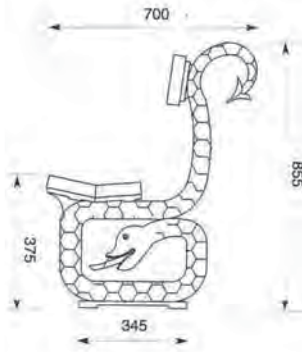

BE015 Front: H375mm

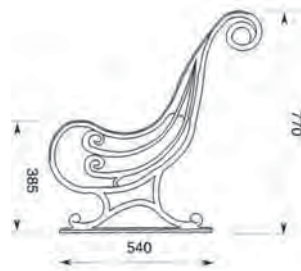

BE016 Front: H385mm Cl:20kg

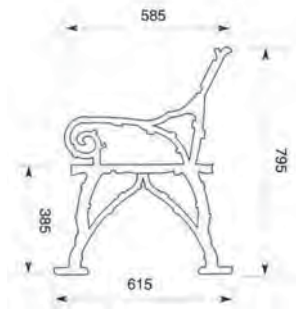

BE017 Front: H385mm Cl:16kg

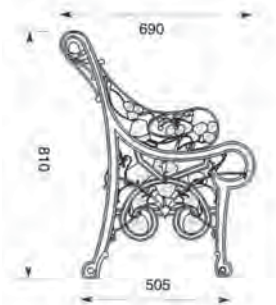

BE018 Cl:68kg

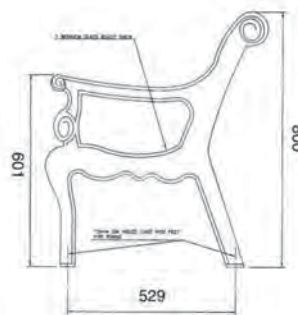

BE019 Front: H601mm Cl:46kg





Cast Iron Bollards

Our bollards are all produced in our foundry using traditional methods. We have a broad range of bollards that can be adapted for a number of different uses from chain barriers to cycle stands. Our bollards are all produced in the UK using traditional foundry methods and we have a design to suit any occasion. If you cannot find something to suit in this catalogue we are constantly adding to our designs through partnerships with councils, architects and private individuals to create truly bespoke products.

Purchasing Guide

- Insignias, lettering and coats of arms can be added to any bollard.
- Eye bolts can be added to allow for chain links.
- We can produce these items in both cast and ductile iron. In an area where there is a possibility of vehicular or mechanical impact, or a high chance of vandalism, we would highly recommend using ductile irons.
- Some bollards are available in removable options.
- Final painting and powder-coating is available on these products.
- Reflective bands can be applied. Colours are available on request.

ORDER TODAY!

CALL: +44 (0)1506 822 721

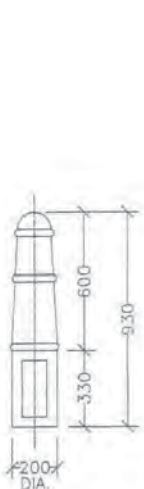

BL001 Cl:47kg

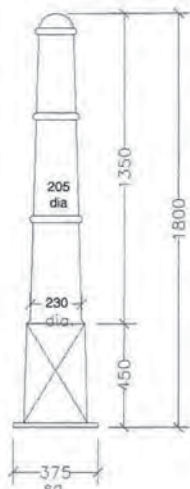

BL002 Cl:168kg



BL003 Cl:83kg

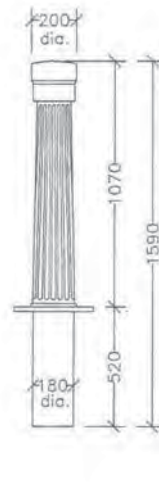

BL004 Cl:94kg

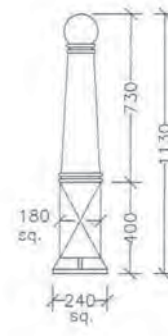

BL005 Cl:61kg

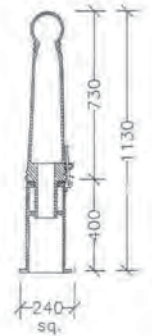

BL006 Cl:74kg

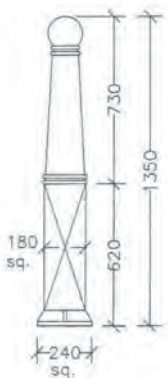

BL007 Cl:75kg

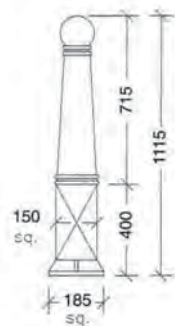

BL008 Cl:38kg

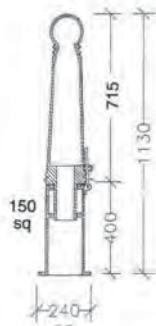

BL009 Cl:46kg

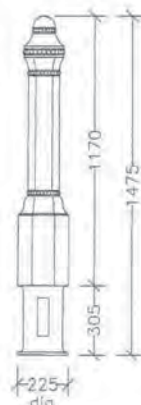

BL010 Cl:90kg

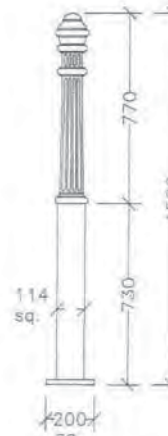

BL011 Cl:67kg

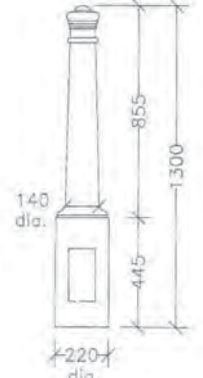

BL012 Cl:46kg



Cast Iron Bollards continued

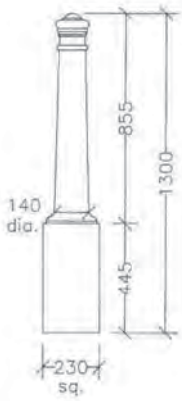

BL013 Cl:88kg

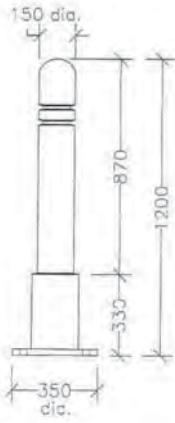

BL014 Cl:75kg

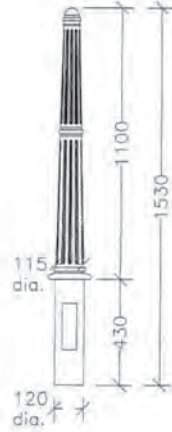

BL015 Cl:43kg

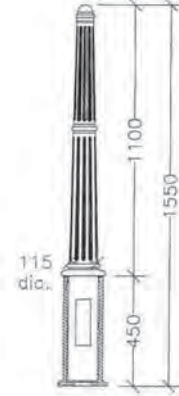

BL016 Cl:63kg

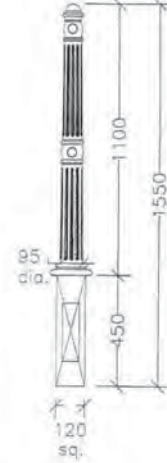

BL017 Cl:41kg

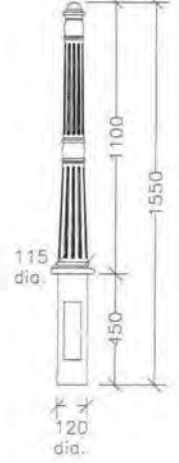

BL018 Cl:43kg

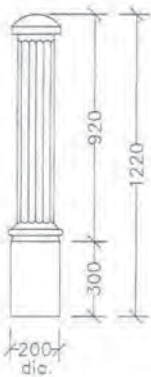

BL019 Cl:53kg

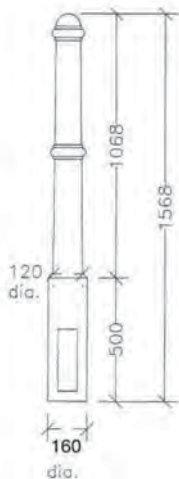

BL020 Cl:47kg

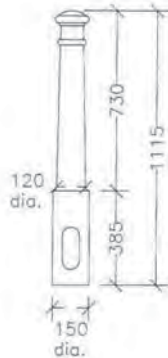

BL021 Cl:74kg

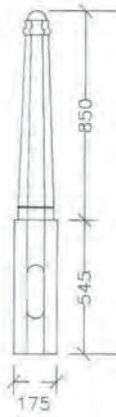

BL022 Cl:75kg

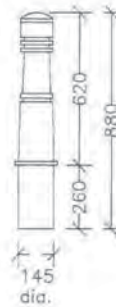

BL023 Cl:38kg

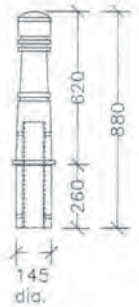

BL024 Cl:46kg

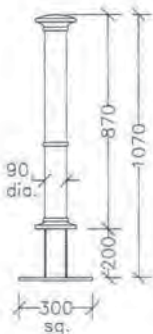

BL025 Cl:90kg

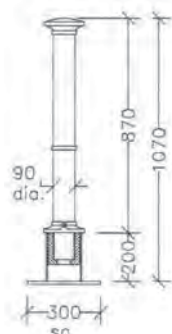

BL026 Cl:20kg



BL027 Cl:36kg

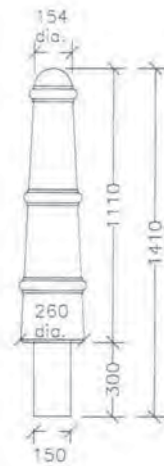

BL028 Cl:192kg

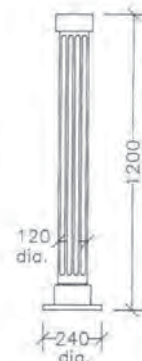

BL029 Cl:58kg

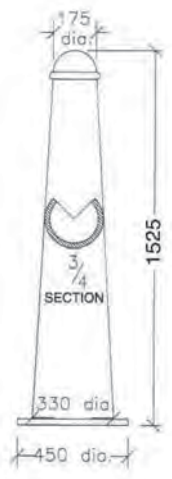

BL030 Cl:192kg



Cast Iron Bollards continued

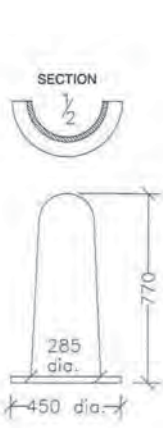

BL031 Cl:45kg

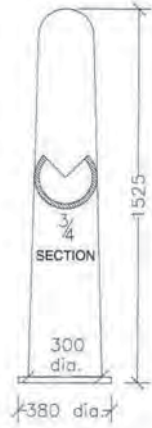

BL032 Cl:140kg

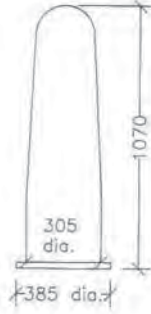

BL033 Cl:84kg



BL034 Cl:62kg

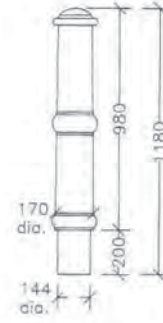

BL035 Cl:66kg

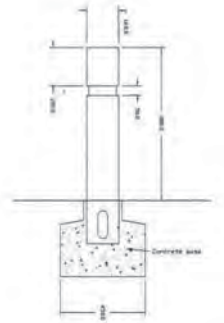

BL036 Cl:22kg

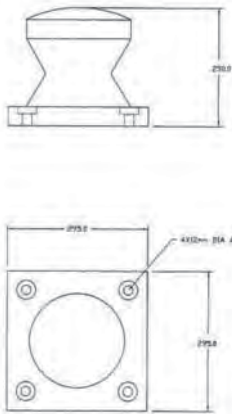

BL037 Cl:101kg

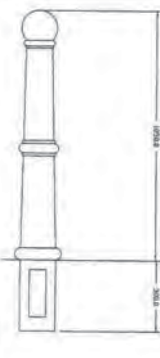

BL038 Cl:40kg

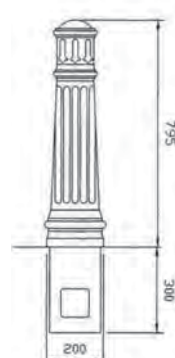

BL039 Cl:55kg

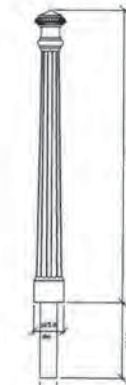

BL040 Cl:70kg



BL041 Cl:143kg

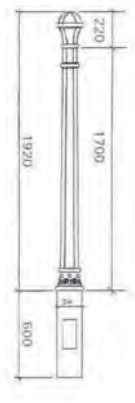

BL042 Cl:113kg

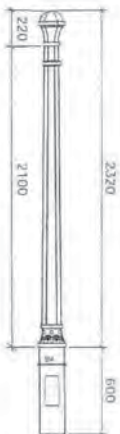

BL041 Cl:143kg

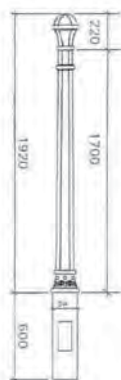

BL042 Cl:113kg



BL043 Cl:47kg

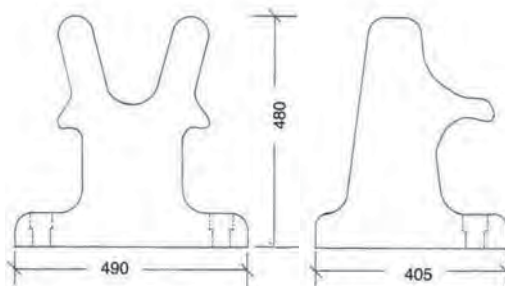

BL044 Cl:250kg



Tree Grilles

We have an extremely wide and varied selection of tree grilles and are constantly adding to our selection. Tree grille patterns are relatively straight forward to make which allows local authorities and private individuals to have their own personal designs. In this age of standardisation and uniformity this flexibility is becoming increasingly popular.

Purchasing Guide

- All tree grilles are designed as a unit to provide an anti-vandal solution and level installation which does not require an expensive sub-frame.
- Tree grilles can have sub-surface lugs to bolt together.
- Lugs can be added to take tree grille fittings.
- Frames can be supplied in both mild steel and cast iron.
- Tree grilles and frames are produced in cast iron and ductile iron only.

ORDER TODAY!

CALL: +44 (0)1506 822 721



G000 11120 O/D x 8920 I/D
x 25mm Thick Cl:99kg

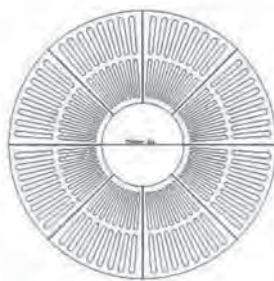

G001 2440 O/D x 750 I/D
x 25mm Thick Cl:480kg

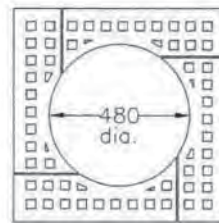

G002 725 x 725 x 480 I/D
x 25mm Thick Cl:46kg

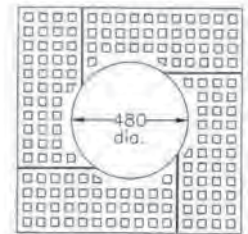

G003 925 x 925 x 480 I/D
x 25mm Thick Cl:84kg



G004 1525 O/D x 450 x 600 I/D
x 25mm Thick Cl:127kg

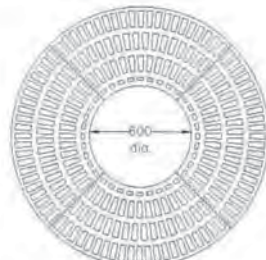

G004A 1525 O/D x 600 I/D
x 25mm Thick Cl:124kg

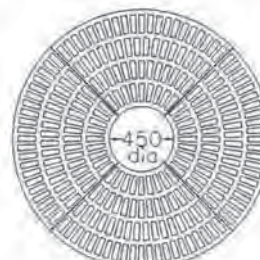

G004B 1800 O/D x 450 I/D
x 25mm Thick Cl:190kg

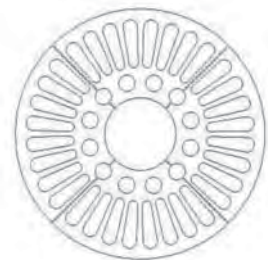

G005 1220 O/D x 350 I/D
x 20mm Thick Cl:88kg



G005A 2000 x 450 I/D
x 20mm Thick Cl:94kg

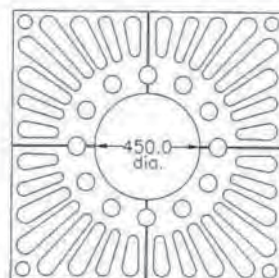

G006 1156 x 1156 x 450 I/D
x 25mm Thick Cl:116kg

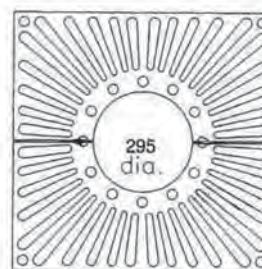

G006A 768 x 768 x 295 I/D
x 25mm Thick Cl:45kg

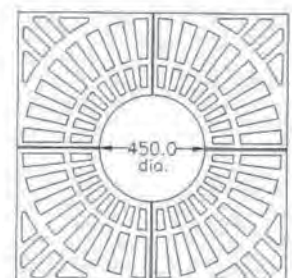

G007 1156 x 1156 x 450 I/D
x 25mm Thick Cl:112kg



Tree Grilles continued

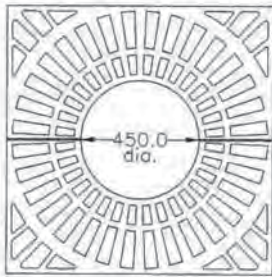

G007A 1014 x 1014 x 450 I/D
x 25mm Thick Cl:86kg

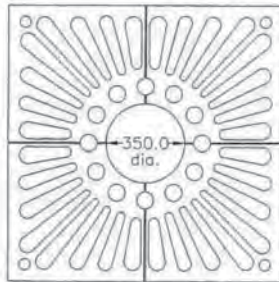

G008 1220 x 1220 x 350 I/D
x 25mm Thick Cl:86kg

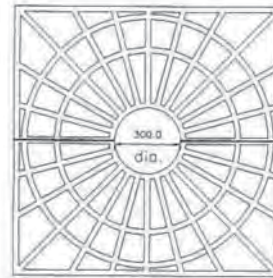

G009 1220 x 1220 x 300 I/D
x 25mm Thick Cl:109kg

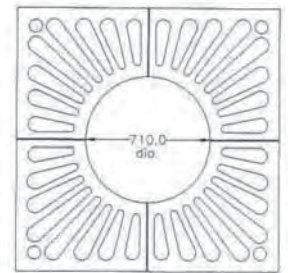

G010 1500 x 1500 x 710 I/D
x 25mm Thick Cl:184kg

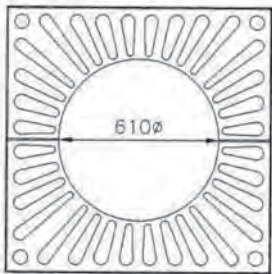

G010A 1000 x 1000 x 610 I/D
x 25mm Thick Cl:72kg

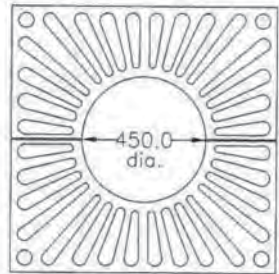

G010B 968 x 968 x 450 I/D
x 25mm Thick Cl:84kg

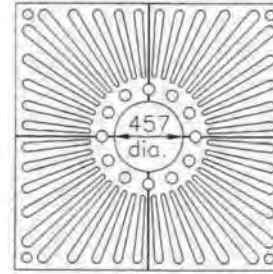

G011 1768 x 1768 x 457 I/D
x 25mm Thick Cl:284kg

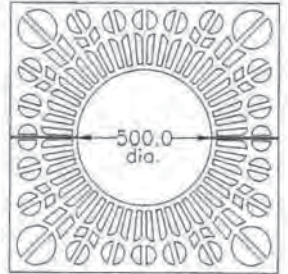

G012 1000 x 1000 x 500 I/D
x 25mm Thick Cl:84kg



G012A 1000 x 1000 x 350 I/D
x 25mm Thick Cl:94kg

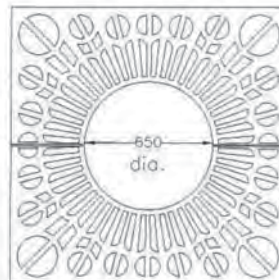

G012B 1400 x 1400 x 650 I/D
x 25mm Thick Cl:154kg

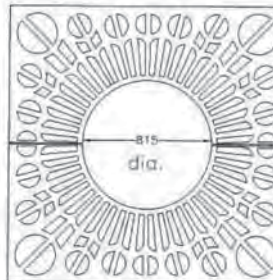

G012C 1750 x 1750 x 815 I/D
x 25mm Thick Cl:218kg

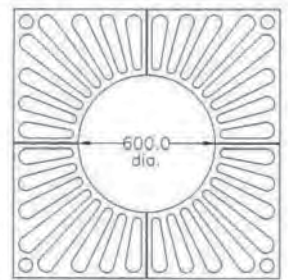

G013 1170 x 1170 x 600 I/D
x 25mm Thick Cl:284kg

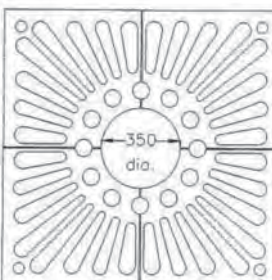

G013A 1220 x 1220 x 350 I/D
x 20mm Thick Cl:108kg

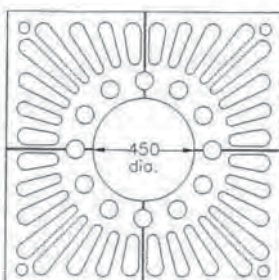

G013B 1220 x 1220 x 450 I/D
x 20mm Thick Cl:106kg

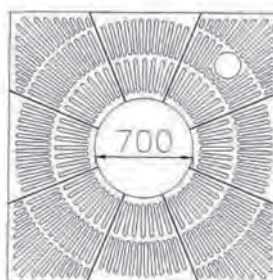

G140 1930 x 1930 x 700 I/D
x 25mm Thick Cl:303kg

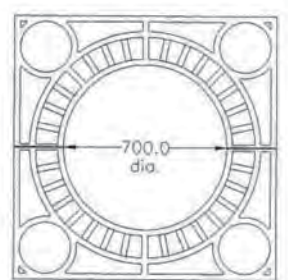

G141A 1125 x 1125 x 700 I/D
x 25mm Thick Cl:71kg



Tree Grilles continued

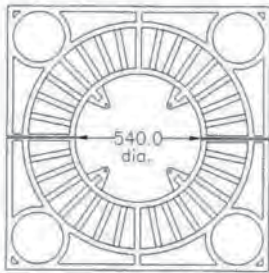

G141B 1125 x 1125 x 540 I/D
x 25mm Thick Cl:78kg

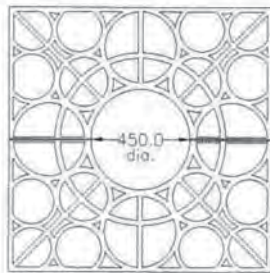

G142 1200 x 1200 x 450 I/D
x 25mm Thick Cl:94kg

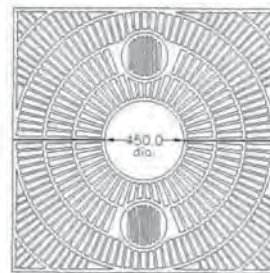

G144 1125 x 1125 x 700 I/D
x 25mm Thick Cl:71kg

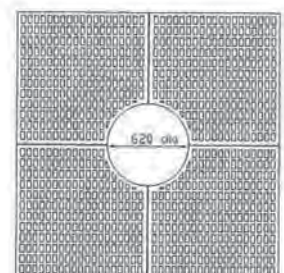

G145 1125 x 1125 x 540 I/D
x 25mm Thick Cl:78kg

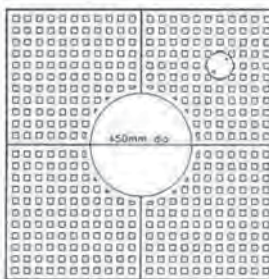

G146 1188 x 1186 x 450 I/D
x 25mm Thick Cl:140kg

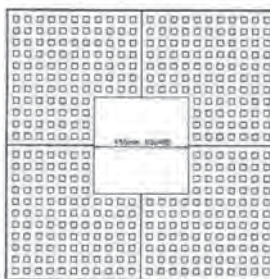

G147 1200 x 1200 x 450 Square
Centre x 20mm Thick Cl:140kg

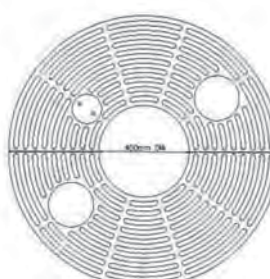

G148 1200 O/D x 400 I/D
x 25mm Thick Cl:95kg



G150 1200 x 1200 x 25mm with motif
castings Cl:110kg



G150A 1220 x 1220 x 350
x 20mm Thick Cl:102kg



G151 1300 x 1300 x 500 I/D
Cl:110kg

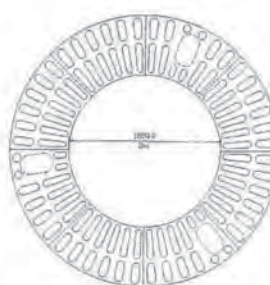

G152 1800 I/D x 3200 O/D with
lighting apertures Cl:84kg

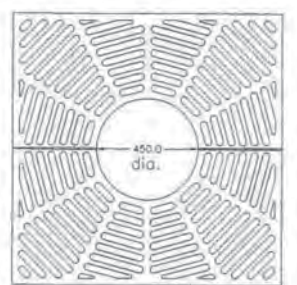

G155 1220 x 1220 x 450 I/D
x 25mm Thick Cl:110kg

Tradition, Heritage, Craft
Hand Crafted Architectural Castings

ENGINEERING CASTINGS
GREENSAND CASTINGS
METALLURGY
PATTERN MAKING
DESIGN AND CONSULTANCY
QUALITY



Ballantine Castings Ltd.
Links Road, Bo'ness EH51 9PW
Scotland UK

T: 01506 822 721
F: 01506 827 326
E: sales@ballantineboness.co.uk
www.ballantinecastings.co.uk



Company Registration: SC471288